

BIGGER. BETTER. BOLDER.



GE T700/CT7 Support Capabilities



As a worldwide leader in helicopter maintenance, repair, and overhaul, StandardAero is committed to providing the highest standards of quality, reliability, and customer service to more than 3,000 customers in over 85 nations.

StandardAero has an established reputation as a provider of T700/CT7 MRO services to military and civil operators worldwide. Our customers include:

- Royal Canadian Air Force
- Royal Netherlands Air Force
- Royal Thai Navy
- Royal Jordanian Air Force
- Egyptian Air Force
- UAE Joint Air Command
- Swedish Armed Forces
- Colombian Armed Forces
- Various U.S. civil and public use operators

We have a demonstrated commitment to delivered excellence, including TAT, pass-off performance and warranty support. As a GE-authorized T700/CT7 MRO provider, our services meet or exceed OEM standards.

Our Canadian-based T700/CT7 MRO facility is supported by a global network of 20 StandardAero facilities and a Mobile Repair Team (MRT) of 150 dedicated employees worldwide.

In addition to T700 MRO, StandardAero offers capabilities for cross-fleet support, including MRO on other turboshaft engine models, helicopter airframe and dynamic component MRO, engine accessory MRO, and aircraft management and design services.

StandardAero is the first independent MRO specialist to be appointed as a GE T700 Authorized Maintenance, Repair and Overhaul Provider (AMROP). This designation allows full access to OEM technical data and specifications, ensuring high-quality MRO services.

StandardAero is also one of only two independent MRO providers to be awarded U.S. DoD T700 source approval (Army & Navy).

Variants supported:



T700/CT7 Capabilities

StandardAero offers a range of responsive, high-quality T700/CT7 services, including:

- Engine/module repair & overhaul
- In-house test cells
- Assembly, integration and test (AIT)
- Model conversions
- Borescope inspection
- Failure analysis
- Component repair
- Foreign object damage (FOD) repair
- Parts support
- Service bulletin (SB) compliance
- Engineering support
- Worldwide field service

Our T700/CT7 component repair and overhaul (CRO) capabilities are as follows:

	OEM repairs	In-house match grinding	High speed match grinding	In-house ECI	EDM machining	Flow capability	Re-coating	Balancing	Pyrolizing cleaning & testing	In-House water flow	Dynamic balancing
Power turbine rotor components	•	•	•								
Power turbine drive shaft components	•	•		•							
Power turbine stator components	•	•		•							
Exhaust frame components	•										
Inlet section	•										
Output shaft assembly	•				•						
Compressor stator assembly	•	•				•					
Compressor rotor assembly	•	•	•				•				
Diffuser midframe assembly	•										
Fuel injector								•			
Combustion liner	•										
Gas generator rotor assembly		•	•						•	•	
Gas compressor stator assembly	•	•									

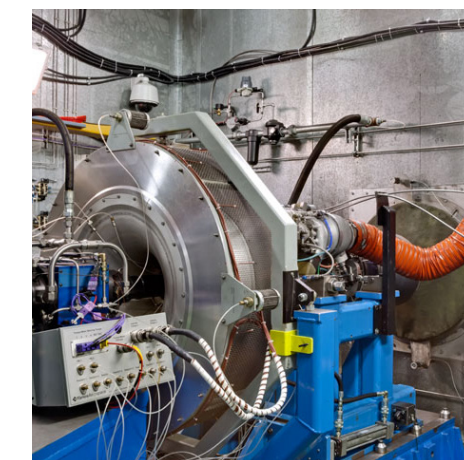

Power Turbine Rotor & Drive Shaft Components

- OEM repairs (rotor & turbine)
- High speed match grinding (rotor)
- In-house ECI (rotor)
- In-house match grinding (turbine)
- EDM machining (turbine)

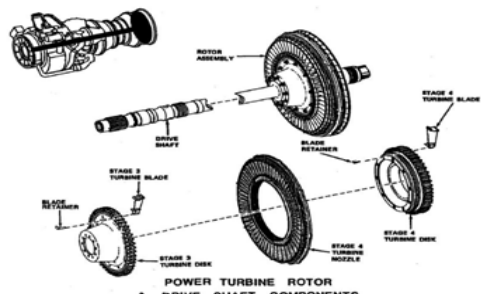

Exhaust Frame Components

- OEM repairs

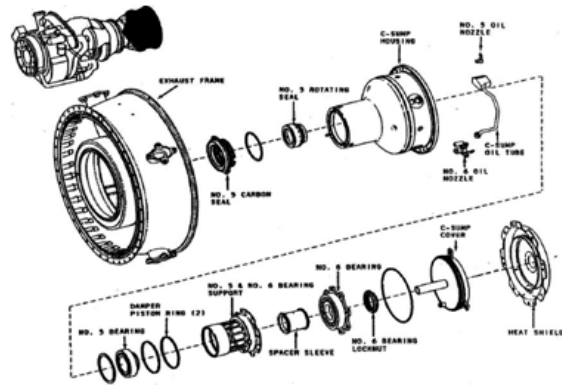

Output Shaft Assembly

- OEM repairs
- In-house flow capability

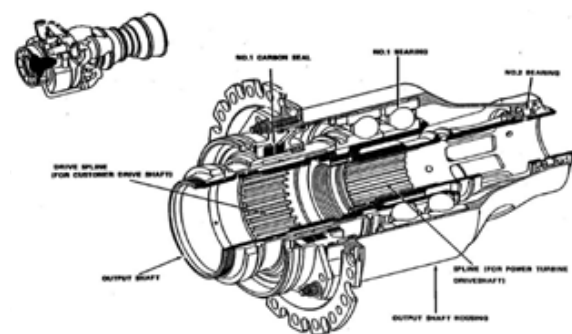

Power Turbine Stator Components

- OEM repairs
- In-house match grinding
- EDM machining

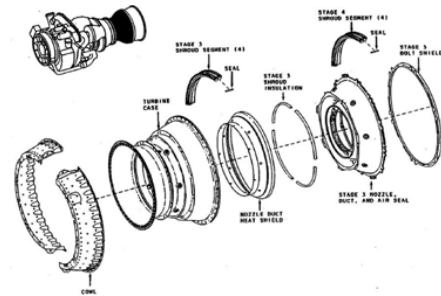

Inlet Section

- OEM repairs

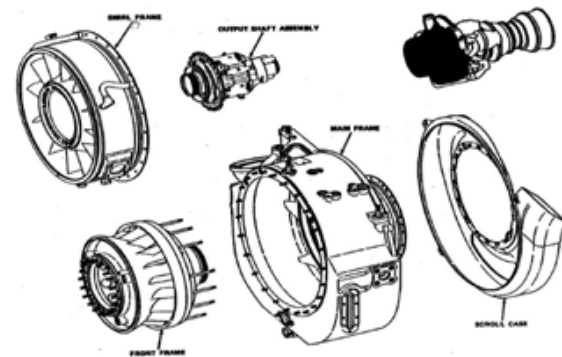

Compressor Stator Assembly

- OEM repairs
- In-house match grinding
- Re-coating

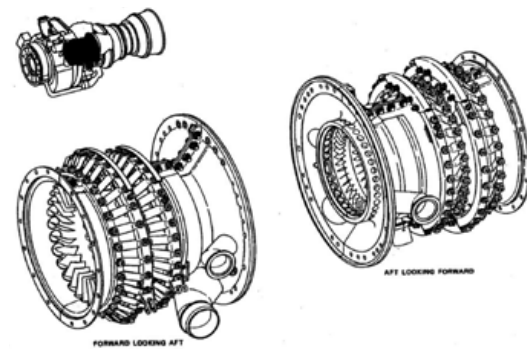

Compressor Rotor Assembly

- OEM repairs
- In-house match grinding
- In-house ECI
- Balancing

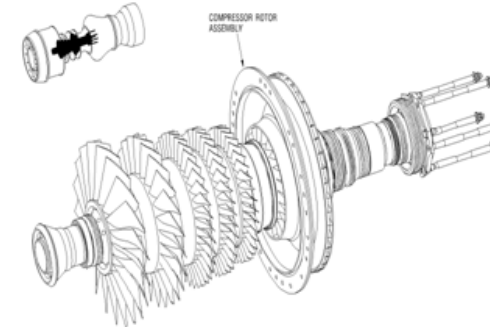

Diffuser Midframe Assembly

- OEM repairs

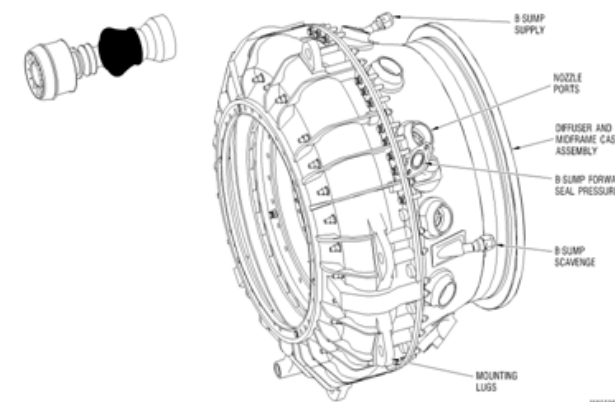

Gas Generator Rotor Assembly

- In-house high speed match grinding
- In-house ECI
- In-house water flow
- Dynamic balancing

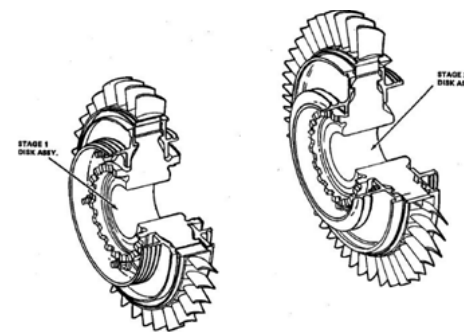

Fuel Injector

- Pyrolyzing cleaning & testing

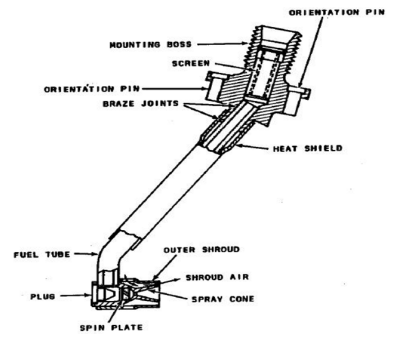

Combustion Liner

- OEM repairs

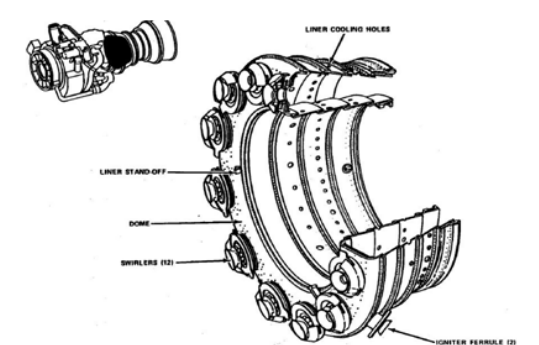

Gas Compressor Stator Assembly

- OEM repairs
- In-house match grinding

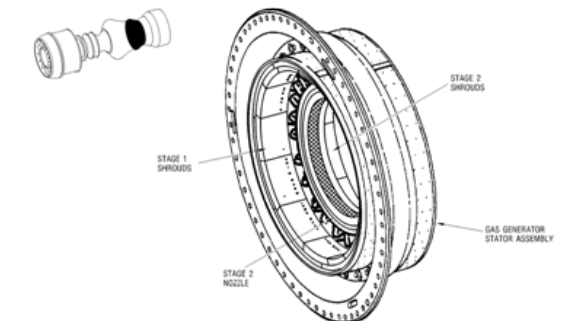

BIGGER. BETTER. BOLDER.

Richmond
20699 Westminster Highway
Richmond, British Columbia, Canada V7C 4V4
Tel: +1 604.276.7600